

# PRESET TIMER

MC5PT



**ANJANA  
ELECTRONICS**

## FEATURES

MICROCONTROLLER  
BASED DESIGN.

NO BATTERIES  
REQUIRED FOR  
DATA RETENTION.

FEATHERS TOUCH  
KEY FOR  
PROGRAMMING/SETTING.

UP/DOWN COUNTING  
BY INTERNAL LINK  
SELECTION.

REMOTE  
START/STOP/RESET  
(OPTIONAL).

9 DIFFERENT  
RANGES / RESOLUTION.

## TECHNICAL SPECIFICATIONS

INPUT POWER SUPPLY	110/230V AC $\pm$ 10% 50Hz
TYPE OF DISPLAY	5 digit, 0.5" Red LED for process value 1 digit, 0.5" green LED for sec/min/hr
CLOCK INDICATION	Green LED 'h' segment
RANGE & RESOLUTION	User selectable 9 different resolution and range
COUNT	Up or down
ACCURACY	$\pm$ 0.05 % Crystal controlled
SET VALUE	Within entire range
PROGRAMMING	Through feather touch key provided in the front panel
RESET, START AND STOP	Panel and remote
TIMER DESIGN	Embedded
MEMORY BACK UP	Internal NV RAM (no battery required)
MEMORY RETENTION	5 years
RELAY OUTPUT	Potential free of Contact rating @ 230V AC/5A.
RELAY ON INDICATION	5mm Red LED
OPERATING TEMPERATURE	0 - 50°C
TERMINATION	Screw Terminals provided in the Rear panel
MOUNTING	Panel Mounting
DIMENSIONS (Hx WxD)	96 X 96 X 130mm
PANEL CUTOOUT (Hx W)	92 x 92 mm
ENCLOSURE	ABS-Plastic
NET WEIGHT	450gm(approx)

\*The above specifications are subject to change without prior notice due to continuous R & D. E&O.E.



## MOUNTING DIAGRAM

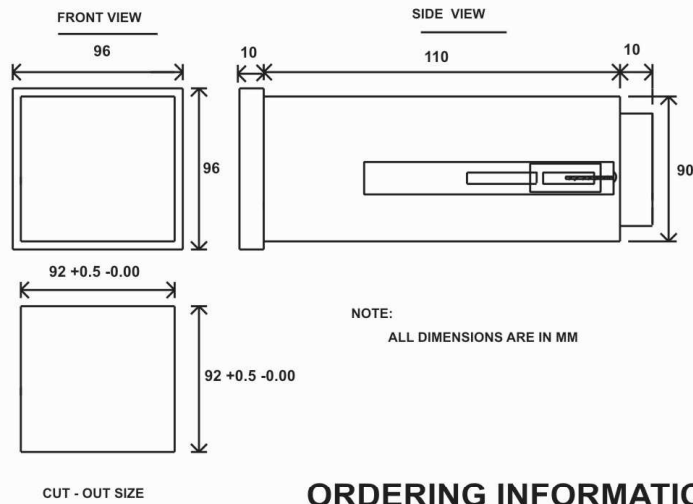

## ORDERING INFORMATION

**M C 5 P T**

**M C 5 P T / X X X X**

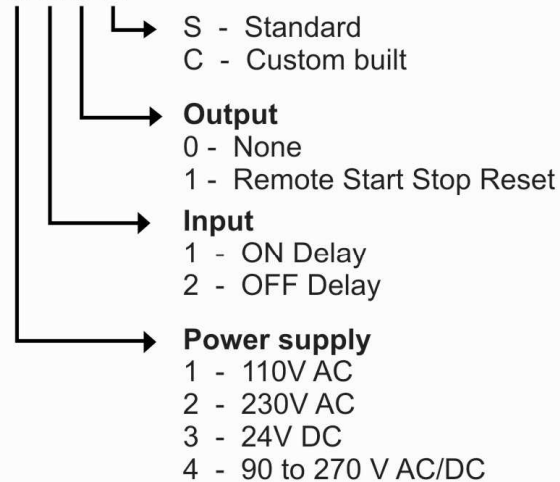

Notes :

### OTHER PRODUCTS :

Bar Graph Indicator, DC Calibrator, Digital Temperature Indicator / Controller, Digital Panel Meter, Fixed Voltage Power Supply, Signal Isolators, Convertors, SMPS Power Supplies, Temp. Transmitters, Counter, Transmitter Power Supply.

### MAJOR CUSTOMER

ASCON MEDICAL INSTRUMENT, AVANTH CARDS, AUDCO, BALMER LAWRIE & CO LTD., BHEL, BEML, ETPS, EURO THERM, ENTECH CONSULTANCY, ETDC, FALCON TYRES, ISRO, ISTRAC, KCP, MTL SYSTEM LTD., MEL SYSTEMS LTD., MTPS, MYPOL, AND OTHER MAJOR SUGAR INDUSTRIES ETC.,

### VALID GOVT. REGN.

SSI/NSIC, DGS & D, SOUTHERN RAILWAY, ICF, ATOMIC ENERGY, SOUTH CENTRAL RAILWAY



**ANJANA ELECTRONICS PRIVATE LIMITED**

### **OFFICE**

: #.4, NEW #.7 47TH STREET, 9TH AVENUE ASHOK NAGAR, CHENNAI - 83.

### **FACTORY**

: #.5, THANGAIYAN STREET, MADHA NAGAR EXTN.V, MADANANDAPURAM, PORUR, CHENNAI -116. PH : 23820440, TELEFAX: 23820371. E-mail aejlin@yahoo.co.in website : www.anjanaelectronics.com

### **BRANCH OFFICE/DEALER :**